

# Aqua-Jet<sup>®</sup>

Surface Mechanical Aerator  
50 Hz



AQUA-AEROBIC SYSTEMS, INC.  
A Metawater Company

# Aqua-Jet®

## Surface Mechanical Aerator

The Aqua-Jet® aerator is the most durable, highly efficient wastewater aerator on the market today. Since 1969, more than 130,000+ Aqua-Jet aerators have been installed throughout the world, representing 1.7 million kilowatts and over 9 billion hours of runtime.

Engineered for robust design and use of the highest quality materials have also made the Aqua-Jet the most trusted aerator in the industry with over 11 patents in design enhancements.

## System Features and Advantages

- Vibration limiting design; velocity of 7.5 millimeters/second or less
- Proven oxygen and mixing performance
- Easy and flexible installation
- Short lead times
- Easily incorporated into existing plants
- Units are retrievable for easy access
- Various mooring arrangements available
- Endura® Series low maintenance motors save energy, reduce O&M costs and increase performance

### Aqua-Jet® Components

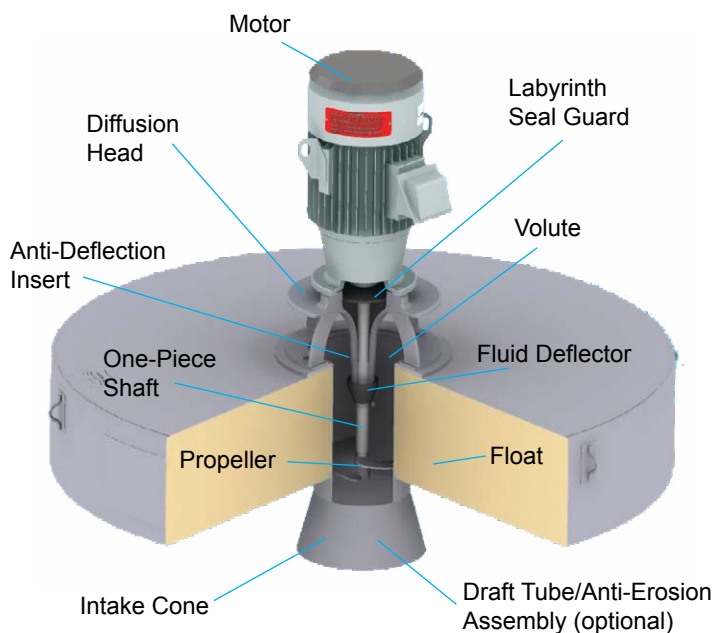

**Motor** - standard 3-year warranty, severe duty, totally enclosed fan-cooled (TEFC), Class F insulation, 1.15 service factor

**Diffusion Head** - monolithic casting, 304 stainless steel (ss), limits vibration

**Motor Shaft** - one-piece, 17-4 precipitation hardened (PH) ss, eliminates couplings

**Float** - Fiberglass or 304 ss exterior. Interior closed-cell polyurethane foam adds structural stability and prevents sinking. Heavy wall ss volute.

**Propeller** - two-blade design precision cast, 316 ss or 15-5 ss, non-clog operation

**Intake Cone/Anti-Vortex Cross** - 304 ss, provides minimum head loss

### Aqua-Jet® Operation

The Aqua-Jet aerator is a mechanical direct-drive unit designed to provide optimum oxygen transfer in a variety of municipal and industrial wastewater applications. The performance of the Aqua-Jet aerator also provides the mixing necessary to uniformly disperse oxygen and organic matter within the microbial population.

#### How it Works

Basin water is pumped up into the intake cone and through the volute, and is dispersed through the diffusion head in a spray pattern. Oxygenation occurs at two critical points:

**1)** when the water exits the diffusion head and **2)** when the spray enters the water surface.

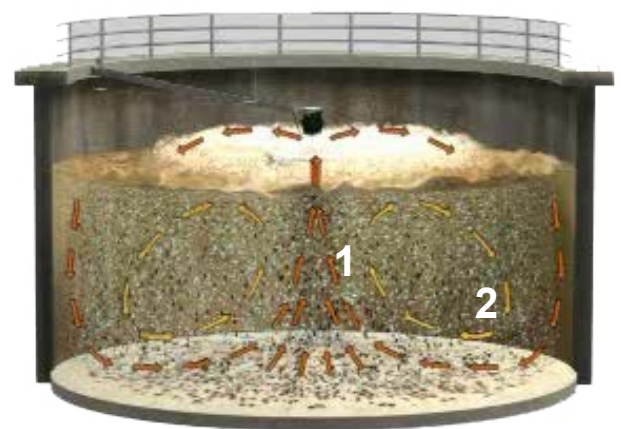

Typical Aqua-Jet® aerator operation.

# Aqua-Jet® Unit Sizes and Dimensions

## SS Series (Stainless Steel)

SS Model	kW (50 Hz)	RPM	Approx Ship Wt (kg)	DIMENSIONS (cm)					Shaft Dia.
				A	B	C	D	E	
30H0101	0.7	1500	91	88.1	20.3	10.2	19.1	118.8	2.2
30H0201	1.5	1500	91	103.0	21.6	10.2	27.9	151.1	3.18
30H0301	2.2	1500	152	112.1	21.6	12.7	27.9	151.1	3.18
30H0501	3.7	1500	186	112.1	21.6	13.3	27.9	151.1	3.18
30H0701	5.5	1500	213	131.3	26.4	17.1	30.5	177.8	4.45
30H1001	7.5	1500	372	131.3	26.4	15.2	30.5	177.8	4.45
30H1501	11	1500	408	193.7*	71.1*	15.9	34.3	210.5	5.40
30H2001	15	1500	581	203.1*	71.1*	16.5	34.3	210.5	5.40
30H2501	18.5	1500	653	205.3*	71.1*	17.1	34.3	210.5	5.40
30H3001	22.5	1000	785	220.8	77.8*	24.1	37.8	240.0	5.40
30H4001	30	1000	875	256.7	103.3*	25.4	37.8	291.1	6.35
30H5001	37.5	1000	1,270	256.7	103.3*	22.5	37.8	291.1	6.35
30H6001	45	1000	1,406	261.1	103.3*	25.4	37.8	291.1	6.35
30H7501	55	1000	1,497	261.1	103.3*	25.4	37.8	291.1	6.87

## FSS Series (Fiberglass)

FSS Model	kW (50 Hz)	RPM	Approx Ship Wt (kg)	DIMENSIONS (cm)					Shaft Dia.
				A	B	C	D	E	
42H0101	0.7	1500	125	88.1	21.6	10.2	17.8	118.8	2.2
42H0201	1.5	1500	125	103.0	21.6	10.2	27.9	162.6	3.18
42H0301	2.2	1500	204	112.1	21.6	10.2	27.9	162.6	3.18
42H0501	3.7	1500	250	112.1	21.6	12.7	27.9	162.6	3.18
42H0701	5.5	1500	261	131.3	26.4	15.2	30.5	180.3	4.45
42H1001	7.5	1500	397	131.3	26.4	14.0	30.5	180.3	4.45
42H1501	11	1500	408	193.7*	69.9*	15.2	35.6	213.4	5.40
42H2001	15	1500	572	203.1*	69.9*	17.8	35.6	213.4	5.40
42H2501	18.5	1500	601	205.3*	69.9*	20.3	35.6	213.4	5.40
42H3001	22.5	1000	751	220.8	76.2*	20.3	39.4	240.0	5.40
42H4001	30	1000	980	256.7	103.3*	25.4	37.8	291.1	6.35
42H5001	37.5	1000	1070	256.7	103.3*	25.4	37.8	291.1	6.35
42H6001	45	1000	1205	261.1	103.3*	26.7	37.8	291.1	6.35
42H7501	55	1000	1250	261.1	103.3*	26.7	37.8	291.1	6.87

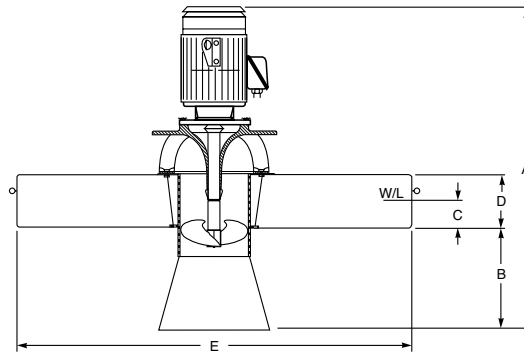

\* Includes allowance for anti-vortex cross. *Dual speed units are available upon request.*

## Typical Aqua-Jet® Aerator Operating Depths (50 Hz)\*

### Activated Sludge

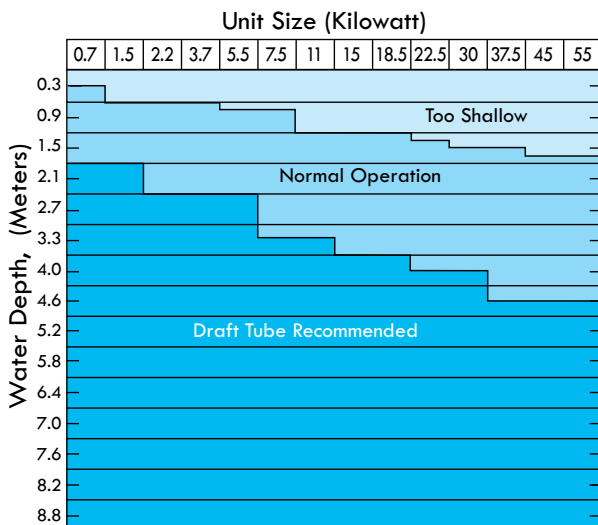

### Aerated Lagoons

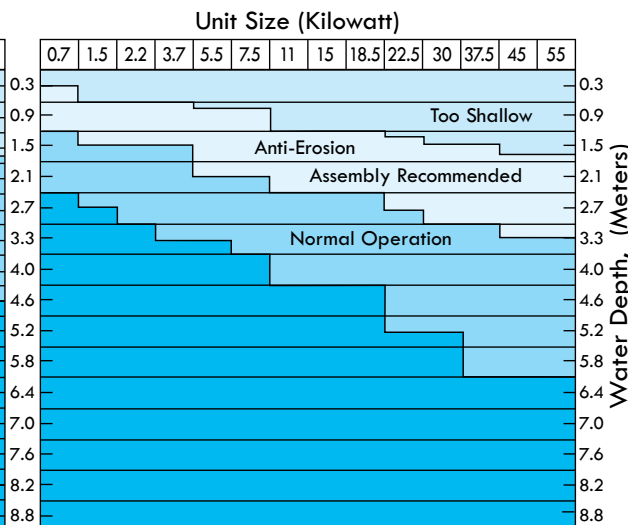

\*These charts are intended for approximation purposes only. Requirements are dependent upon basin geometry.

Consult Aqua-Aerobic Systems for larger kilowatt units or specific applications.

# Aqua-Jet® Typical Applications

- Extended aeration
- Aerobic digestion
- Equalization
- Aerated lagoons
- Oxidation ditches
- Sludge holding
- Municipal-industrial combinations
- Batch reactor processes



## Industrial Applications

- Pulp and paper
- Refineries/petroleum
- Palm oil
- Food and beverage
- Chemical
- Pharmaceutical
- Textile
- Energy/power

## Municipal Application Advantages

- Provides efficient oxygen transfer and complete mixing
- Pivotal Mooring or Restrained Mooring accommodate large changes in water level
- Units can be pulled to the side of the basin for service without dewatering
- Aerator can be cycled on/off to control dissolved oxygen (D.O.) and save energy

# Aqua-Jet® Mooring Arrangements

There are four standard mooring arrangements for the Aqua-Jet aerator. The type selected is dependent on the specific application.

## Post/Maintenance Mooring

A mooring post is installed on shore and the mooring line is attached to an eyebolt in the post. A maintenance loop enables the operator to pull the unit to shore or opposite side of the basin without disconnecting the line. Available for 3 or 4 point mooring.

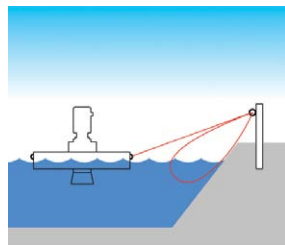

## Span Mooring

Span Mooring is used in larger lagoon applications, allowing more than one (1) aerator to be attached to a single mooring cable across the lagoon. Each aerator is attached to the cable using a 3 point mooring concept and can be removed individually for service (plan view shown to the right).

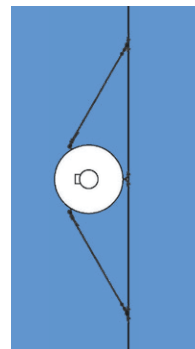

## Restrained Mooring

Restrained Mooring is used in applications with varying water levels. The Aqua-Jet mooring frame fits around the mooring posts and allows the aerator to slide up and down the posts as the water level changes.

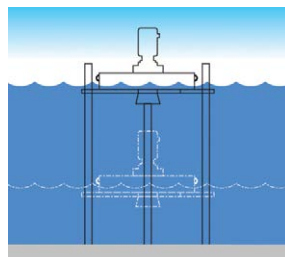

## Pivotal Mooring

A Pivotal Mooring arm is used in applications with varying water levels with arm lengths up to 13 meters. The arm fits at the base of the motor allowing the aerator to adjust to varying water levels.

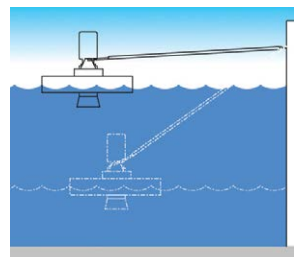

# Accessory Options

## Aqua-Jet II® Contained Flow Aerator

The Aqua-Jet II Contained Flow Aerator is designed for applications which require continued operation of aeration equipment during cold weather months, but are limited because of an inadequate heat sink due to process selection or environmental conditions. This aerator has proven to operate efficiently in a variety of applications, even in sub-zero temperatures. The dome is essentially a spray control shield mounted to the diffusion head of the Aqua-Jet aerator.

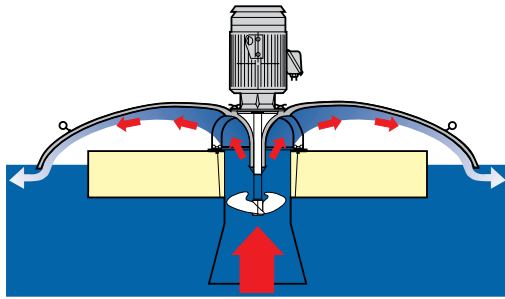

## Anti-Erosion Assemblies

Anti-Erosion Assemblies consist of a stainless steel plate attached to the bottom of the Aqua-Jet aerator intake cone via an anti-vortex cross. The assembly causes water to be drawn from the sides of the intake cone, rather than from directly below it; and prevents damage to the basin liner or erosion of the bottom. Anti-Erosion Assemblies are available for all horsepower Aqua-Jet aerators. Consult your Aqua-Aerobic representative, or the factory for dimensions.

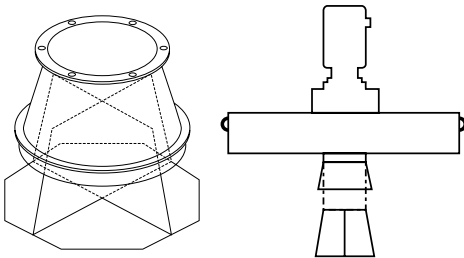

## Draft Tubes

The Draft Tube accessory provides an extension of the intake cone and permits a deeper intake of water. Available in lengths of 0.91 and 1.83 meters.

## Low Trajectory Diffuser (L.T.D.) Assembly

The Low Trajectory Diffuser (L.T.D.) Assembly is a high density polyethylene ring that is attached to the top of the diffusion head, increasing the diameter of the diffuser. This arrangement lowers the spray of the Aqua-Jet aerator reducing windblown spray and misting. Low trajectory diffusers are used in colder climates, and where a smaller, lower spray pattern is desired.

## Arctic Pak

The Arctic Pak ring contains thermal resistance heaters which minimize the chance of icing on exposed surfaces of the Aqua-Jet aerator, such as the cast diffusion head. The Arctic Pak is complete with its own junction box (which mounts on the motor fan cover), automatic controls and control panel. Operation of the Arctic Pak is controlled by an ambient temperature thermostat.

The unit is available in 230 volts and can be used on floating Aqua-Jet aerators. Drawings and wiring diagrams are available on request.



**Since 1969**, Aqua-Aerobic Systems, Inc. has led the industry by providing advanced solutions in water and wastewater treatment. As an applied engineering company serving both municipal and industrial customers, we work collaboratively with consulting engineers, owners, plant managers, and operators to design and manufacture the best treatment solution with the lowest lifecycle cost.

# PROTECTING THE WORLD'S WATER.

**Aeration and Mixing**

**Biological Processes**

**Filtration**

**PFAS Solutions**

**Ozone Systems**

**Membranes**

**Aftermarket Products and Services**

**Rental Programs**

## **Aqua-Jet<sup>®</sup>** **Surface Mechanical Aerator** **50 Hz**

Visit our website at [www.aqua-aerobic.com](http://www.aqua-aerobic.com) to learn more about the Aqua-Jet<sup>®</sup> Surface Mechanical Aerator and our complete line of products and services.



**Follow**



**Subscribe**



**AQUA-AEROBIC SYSTEMS, INC.**  
A Metawater Company

[www.aqua-aerobic.com](http://www.aqua-aerobic.com)  
6306 N. Alpine Road, Loves Park, IL 61111-7655  
p 815.654.2501 | f 815.654.2508 | [solutions@aqua-aerobic.com](mailto:solutions@aqua-aerobic.com)

The information contained herein relative to data, dimensions and recommendations as to size, power and assembly are for purpose of estimation only. These values should not be assumed to be universally applicable to specific design problems. Particular designs, installations and plants may call for specific requirements. Consult Aqua-Aerobic Systems, Inc. for exact recommendations or specific needs. Patents Apply.